

**THE PERFECT SOLUTION
FOR EVERY MIXING TASK**



Food Processing Plants

ENGINEERING YOUR SUCCESS



Zeppelin Systems, the world leading plant manufacturer for high quality bulk material handling, has remarkably grown over the past 60 years. We cover the demands of a wide range of industries and supply all plant manufacturing services from one single source, whether basic engineering, in-house production of components, final assembly or comprehensive customer service. Thanks to our financial strength and our global network, we have long been a reliable partner for our customers.

Every Zeppelin plant is developed according to the clients' specific requirements, and realized, thanks to our customized innovative processes and technologies.

The knowledge we have acquired over more than 60 years of plant manufacturing and the world's largest network for bulk material handling is the key to providing ideal solutions, whatever the challenge; after all, your success is our goal.

Zeppelin plant engineering – business fields

Polyolefin Plants

Plants for plastics producers and forwarders

Plastics & Rubber Plants

Plants for the plastics processors and rubber industry

Food Processing Plants

Plants for the food, confectionery and baking industry

Mixing Technology

HENSCHEL-Mixers®, mixing systems

Silos

Storage silos, mixing silos, process silos

Components

Rotary feeders, diverter valves, discharge and dosing units, sifters, filters ...

Service

Spare parts, customer service and consulting

Modernization/Revamping

Optimization of production lines and plant controls



Container mixer

SPECIFIC REQUIREMENTS – INDIVIDUAL MIXING SOLUTIONS

Efficient production lines with high availability and reproducible product quality can only be achieved with optimum systems technology and a process that is designed for the specific requirements of the respective product. Our systems and mixers guarantee this in continuous and batch-based system solutions.

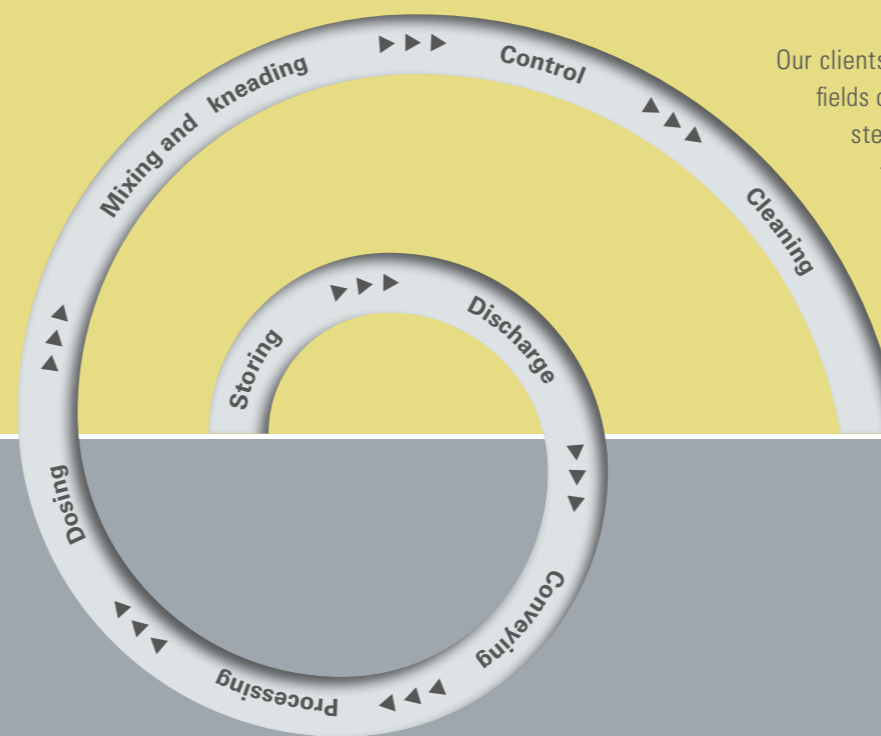

Our clients appreciate our comprehensive know-how in all fields of raw materials handling. We master the process steps and technology from raw material receiving to processing, and develop integrated solutions designed to fit perfectly into the system – from one single source. Our scope naturally includes optimal control technology and professional customer service around the world.

System solutions from a single source

It's the mix that counts

- Baking mixes
- Confectionery
- Spices/instant products
- Cakes/desserts
- Nutritional supplements
- Soups/sauces
- Cereals
- Dough processing
- Baby food



Codos® mixer



Conventional mixing factory

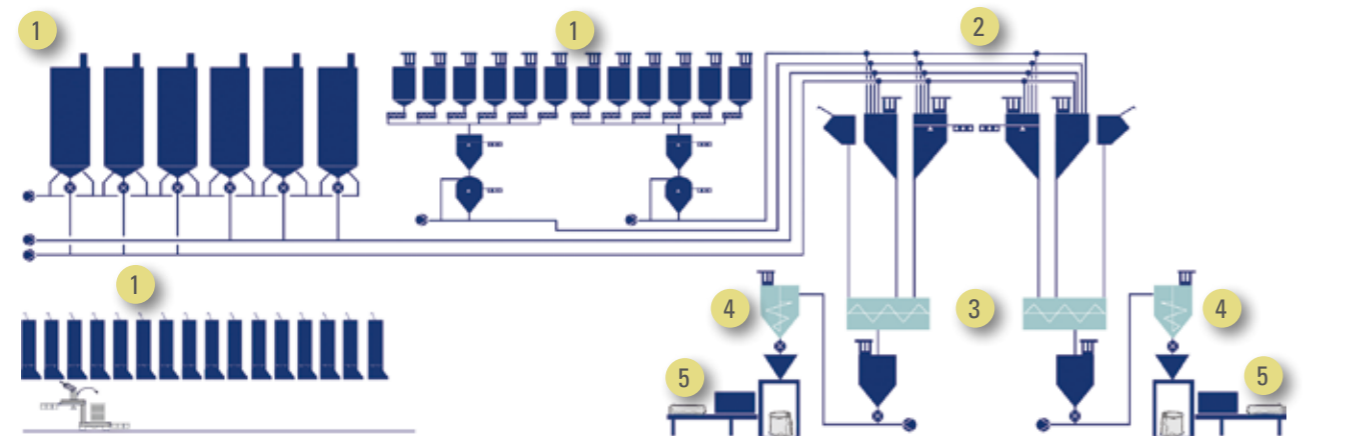

Applications

- Baking mixes
- Spice mixes
- and many more

- 1 Storage of major, medium and minor ingredients
- 2 Scale hopper
- 3 Horizontal mixer
- 4 Conical screw belt mixer
- 5 Packaging line



Mixing plant for dry blends

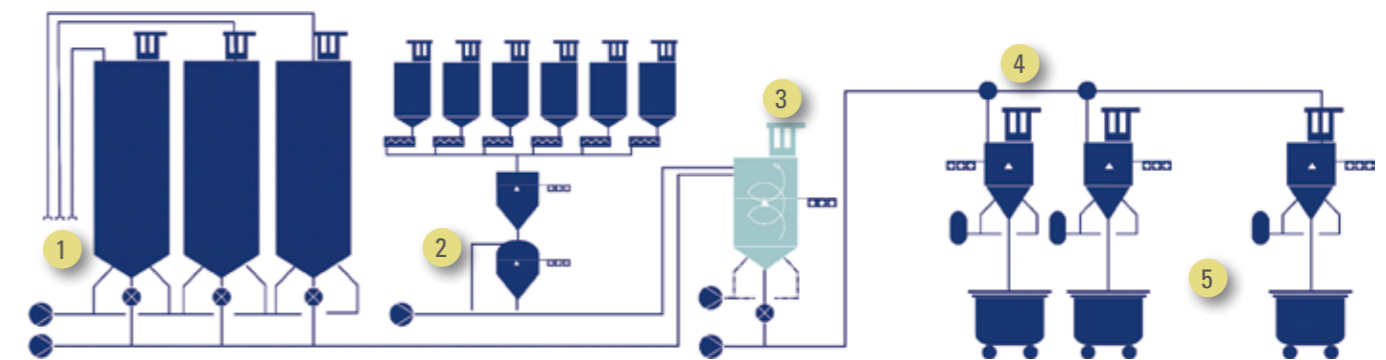

Applications

- Flour blending
- Addition of proteins
- Pasta production
- Nutriment
- and many more

- 1 Storage of major ingredients
- 2 Ingredients line
- 3 Pneumatic mixer
- 4 Scale hopper
- 5 Dough bowl



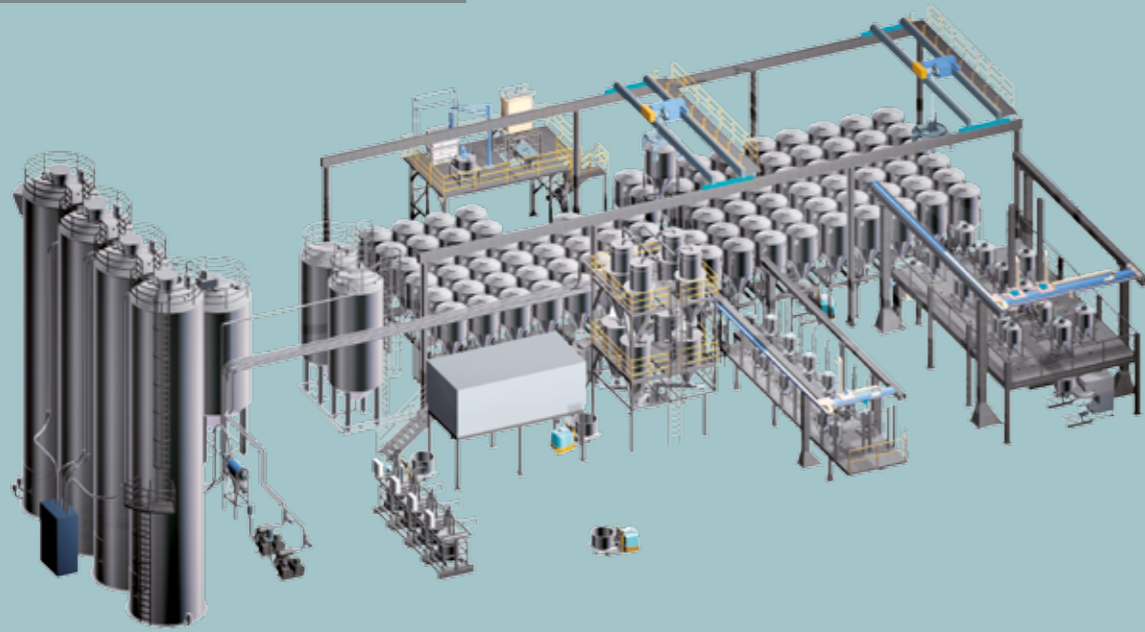

Cookie production

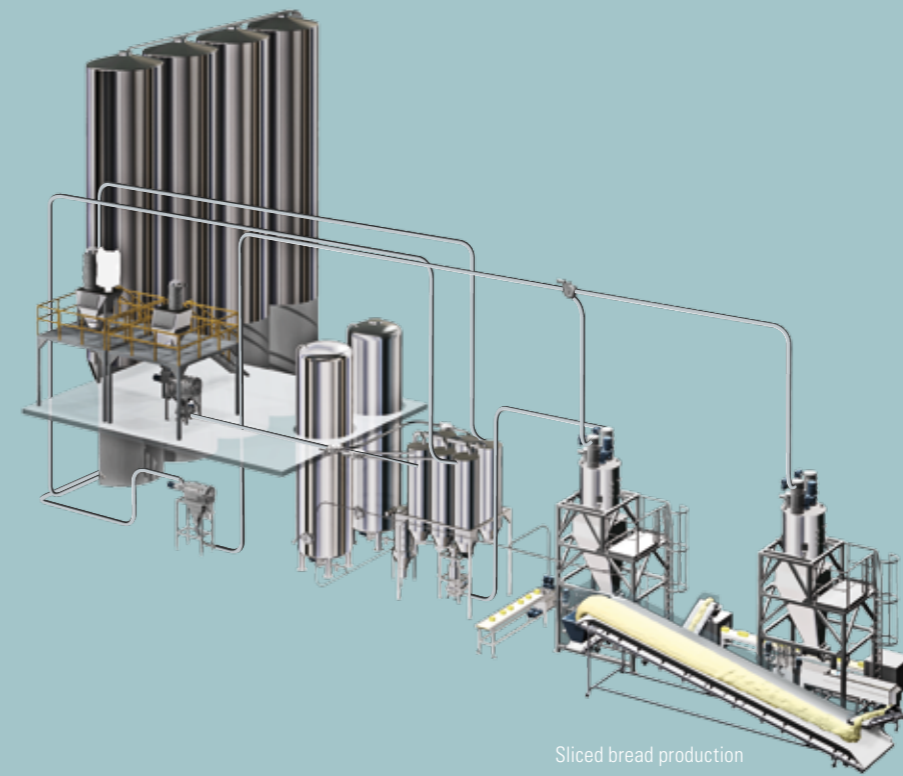

Sliced bread production

Mixing factory based on the ReciPure® concept

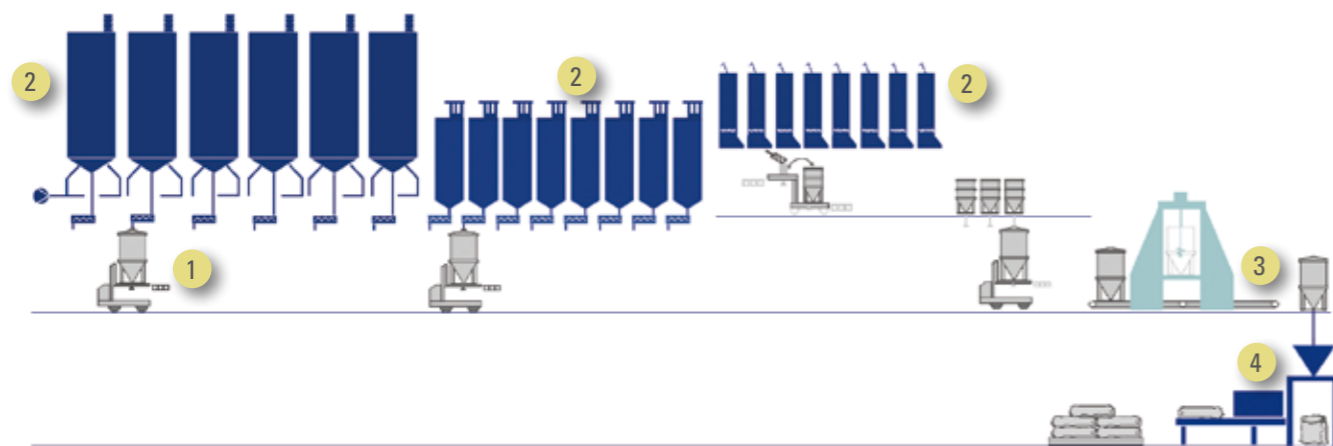

Applications

- Spice mixes
- Baking mixes
- Fresh baked goods
- Confectionery
- Baby food
- and many more

- 1 Container transport systems with integrated scale
- 2 Storage of major, medium and minor ingredients
- 3 Container mixer
- 4 Packaging line



Plant for continuous dough production

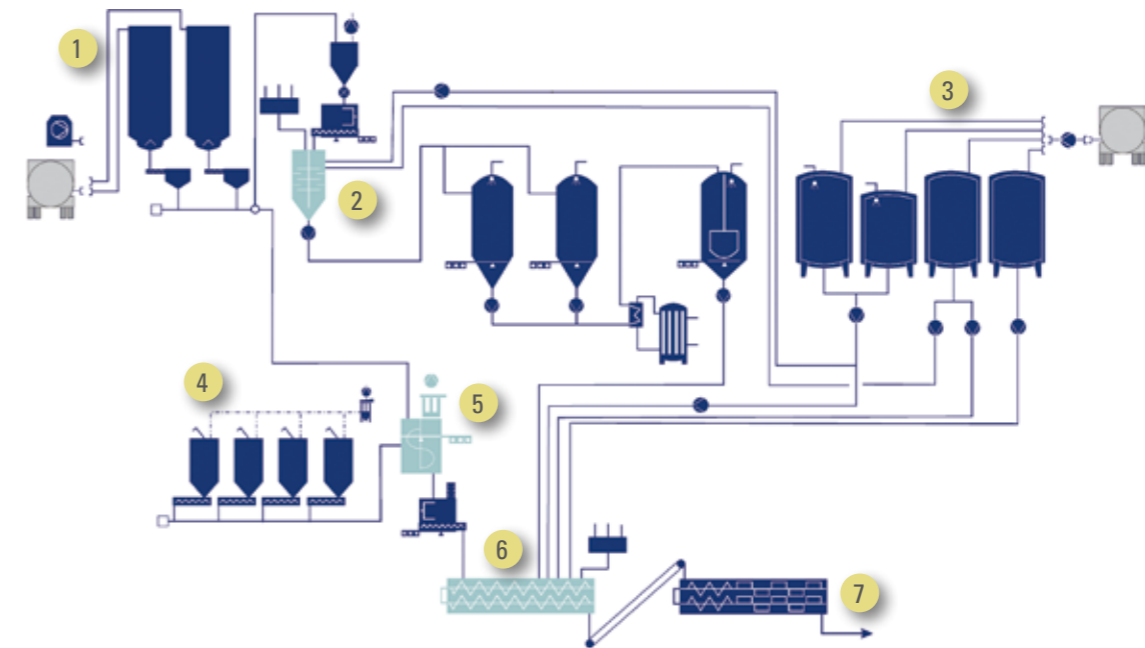

Applications

- Bakeries
- Confectionery industry
- Extended shelf-life baked goods industry
- and many more

- 1 Outdoor storage silo
- 2 Shear flow mixer ShearDos (liquid sponge line)
- 3 Storage tanks
- 4 Ingredients line
- 5 Screw belt mixer
- 6 Codos® mixer
- 7 Codos® kneader



ALWAYS THE PERFECT MIXER

A variety of different mixing tasks needs to be solved in the manufacture of products. Zeppelin provides a wide selection of mixers to meet all requirements.

Pneumatic mixers are used for the homogenization of dry, fine-grained bulk material; fat and other liquid active ingredients can also be added. Pneumatic mixers only require air and no special mixing tools for the gentle mixing of bulk material.

Mechanical mixers, on the other hand, are generally fitted with mixing tools. Mechanical mixers are usually multi-purpose machines with a wide range of applications besides homogenization, e.g. de-agglomeration.

By adding the reliable HENSCHEL-Mixers® to our product portfolio we can cover additional applications.

With our range of optional equipment components we can provide you with a customized Zeppelin mixer designed to meet your production requirements. The following designs are only an excerpt from the possible options. For more details, please refer to the corresponding product descriptions.



Shear flow mixer ShearDos

Design

Vertical cylindrical mixing vessel with a conical base in which shear rods are anchored. A shaft that is also fitted with shear rods rotates within the container. The mixing tools operate according to the rotor/stator principle.

Operating principle

Continuous and intensive mixing of solids and liquids within shear gaps.

Advantages

- Continuous operating mixer ideal for different mixing tasks (solid/liquid)
- Fast mixing
- Adjustable mixing time

Application

Production of suspensions such as liquid sponge and sourdoughs.

Cleaning

- Easy cleaning through mixing lid and two service doors
- Optional: automatic WIP (Washing in place) cleaning available

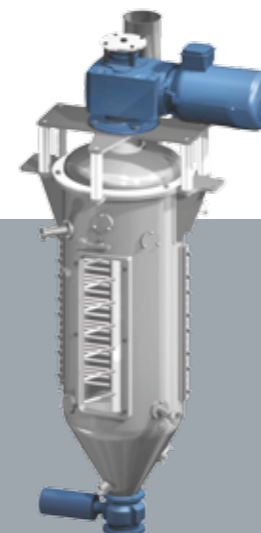

Codos® mixer

Design

Open, continuously operating horizontal mixing vessel with two interlocking mixing tools.

Operating principle

Bulk materials, liquids and/or viscous materials are mixed and conveyed by the counter-rotating screw elements. A constant temperature is provided by a double jacketed trough construction which can be heated or cooled.

Advantages

- Continuous optimum product quality
- Low energy input
- Lump-free and optimum compounding of dry materials and liquids
- Easy to operate

Application

Continuous production of doughs and masses, such as sugar and chocolate masses, frostings, spice pastes, wheat, rye, potato and starch doughs.

Cleaning

- Easy access to all elements by opening the trough lid
- Mixing zone designed for wet cleaning
- Optional: WIP (Washing in place) cleaning

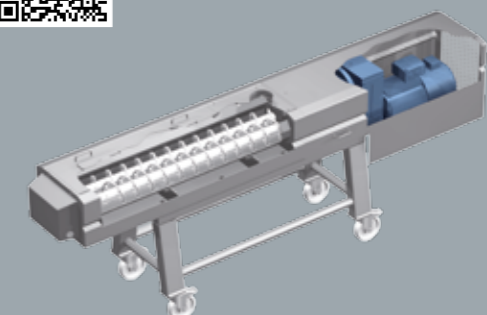

Container mixer

Design

The mixer is composed of a mixing lid with integrated mixing tools. This, together with the docked container, forms the mixing chamber.

Operating principle

All raw materials for one recipe are collected in transportable containers and docked to the mixing head of the container mixer. During mixing the container hopper makes a 180° upwards turn while the tools in the mixer head are rotating. Liquids can be added through a hollow shaft.

Advantages

- Intensive and fast mixing of all components
- Mixing without product adhesion
- Extremely large filling degree range allows the production of varieties of products and quantities on one single machine size
- Ideal for frequently changing recipes
- Residue free complete discharge
- Dust free operation

Applications

- Production of blends from various raw materials such as baking additives, spice blends and baby food
- Embedded in a system solution, container mixers allow production of blends free of contamination with reliable batch traceability

Cleaning

- Easy cleaning of mixing chamber and tools
- Container is cleaned separately from the mixer



Pneumatic mixer

Design

Vertical cylindrical mixing vessel with filter and fluidizing bed.

Operating principle

The air supplied through the chamber fluidizes and mixes the raw materials gently and intensively. The blend can also be heated or cooled through the control of the air temperature. Up to 10% fat and other liquid active ingredients can be added by fitting the mixer with one or more two-component nozzles for the addition of liquids.

Advantages

- Gentle product mixing
- Short mixing time with/without temperature change
- No moving parts in the mixing chamber
- Can be used as a source hopper for dense phase conveying, thereby providing separation-free discharging and conveying
- Liquid dosing
- Optional de-agglomerating device

Applications

- Mixing of fluidizable bulk materials
- Mixing of baking ingredients
- Cappuccino mixes

Cleaning

Easy access through the large inspection and service door and absence of mixing tools ensure good cleaning.



Horizontal mixer

Design

Horizontal cylindrical mixing container, horizontal mixing shaft with revolving mixing tools.

Operating principle

Revolving mixing tools distribute the product in both the circumferential and axial directions, thereby achieving an intensive mixing effect. Special designs are available for gentle mixing with low energy input.

Advantages

- Intensive component mixing
- Short mixing and discharging times
- Dosing of liquids on the surface or below product level
- Optional de-agglomerating device
- Optional double wall design for heating/cooling

Applications

- For mixing tasks from bulk materials with good or poor flowability to liquid or pasty products with a variety of bulk densities
- Homogenizing of up to 10000 L volume

Cleaning

- Easy access to the mixing chamber
- Easy cleaning design and surfaces
- Quick-clean discharge flap

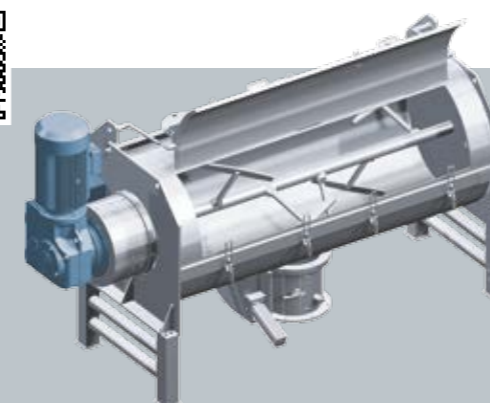

Universal mixer

Design

Vertical cylindrical mixing vessel with vertical mixing shaft and mixing tools rotating close to the vessel bottom.

Operating principle

Rotating mixing tools lift the product up axially and distribute it radially providing gentle but intensive mixing.

Advantages

- Gentle mixing at low revolutions
- Intensive mixing of all ingredients
- Short mixing time
- Good product discharge
- Dosing of liquids on the surface or below product level
- Optional de-agglomerating device
- Optional double wall design for heating/cooling

Applications

- Production of powder mixes
- Production of mixes with various density and grain sizes
- Dosing of liquids

Cleaning

- Easy access to the mixing chamber
- Easy cleaning design and surfaces
- Quick-clean discharge flap
- Many more optional cleaning methods available

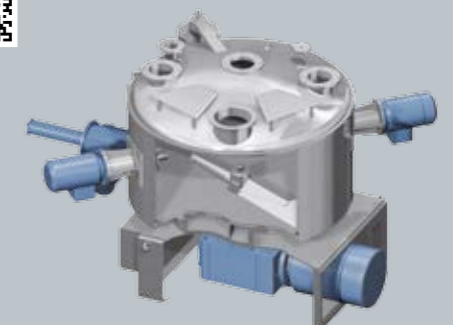

Screw belt mixer

Design

Vertical cylindrical mixing vessel with rotating screw belt mixing tool.

Operating principle

The mixing tool conveys the material upwards close to the wall, creating a downward flow in the center of the vessel.

Advantage

The three-dimensional mixing process results in a very homogeneous mixture.

Application

Production of premixes composed of various flours and baking ingredients.

Cleaning

- Inspection and cleaning hatch for easy access
- Cleaning of the screw belt through air nozzles available as option

Conical screw belt mixer

Design

Vertical cylindrical mixing vessel with a conical outlet and rotating screw belt mixing tool.

Operating principle

The mixing tool conveys the material upwards close to the wall, creating a downward flow in the center of the vessel.

Advantages

- The three-dimensional mixing process results in a very homogeneous mixture
- Very good residue free discharge

Application

Mixing of different flours and baking mixes.

Cleaning

- Inspection and service door for easy access to the mixing chamber
- Cleaning of the screw belt through air nozzles available as option

Paddle mixer

Design

Upright cylindrical mixing vessel with a conical outlet, in the center of which is an agitator shaft with welded-on paddles extending close to the wall.

Operating principle

The product is transported to the top by the upward-facing interlocking paddles and hurled into the free space above the product surface. At the same time, the product in the center of the mixer moves downwards and is collected by the paddles at various points and mixed into the upward-moving product flow.

Advantages

- Intensive mixing
- Short mixing time
- Fast and homogeneous mixing of even minor ingredients
- Complete discharge with almost no residual product

Application

For blends that require fast mixing with high energy input. The paddles disperse agglomerates.

Cleaning

- Easy access through the maintenance door in the lid
- Very little cleaning required thanks to the complete product discharge

Laboratory mixer

Laboratory mixers are little versions of the big production machines. The laboratory machines aim for an accurate downscaling of equipment and functions of the production machines to guarantee appropriate results when laboratory results are scaled up for production.

The machine design is adapted to meet the different handling requirements of raw materials in a laboratory. This usually requires a higher flexibility and better accessibility to all essential controls.





Presented by:

Zeppelin Systems GmbH
Food Processing Plants
Messenhäuser Straße 37 - 45
63322 Rödermark
Germany

Tel.: +49 6074 691 - 0
Fax: +49 6074 6031

foodtechnology@zeppelin.com
www.zeppelin.com

For the complete Zeppelin Systems range please visit our website at
www.zeppelin-systems.com

Global presence

- Belgium
- Brazil
- China
- France
- Germany
- India
- Italy
- Korea
- Russia
- Saudi Arabia
- Singapore
- United Kingdom
- USA